

# PVV204 Series Pressure and Vacuum Vent PVV204-18

The PVV204 series pressure and vacuum relief vents are used on tanker trucks and incorporates roll-over protection. It prevents the build up of pressure and vacuum caused by expansion, contraction and tanker movement.

The vents provide pressure and relief to Australian Standard AS2809 for road, rail and storage tank applications. The PVV204 provides more capacity than the standard PVV104

The vent incorporates roll-over protection such that it locks shut at any angle greater than 60° from vertical.

These vents are used on storage and blending tanks. It is important that the pressure/vacuum volume of the tank is known so that the correct size and number of vents can be supplied.

## Key Features

- Three poppet design.
- Pressure poppet only opens when the internal pressure of the tank exceeds the settings shown below
- Vacuum poppet only opens when the internal pressure of the tank falls below the setting shown below.
- Rollover poppet is always open except when tanker is on an angle greater than 60° from vertical.

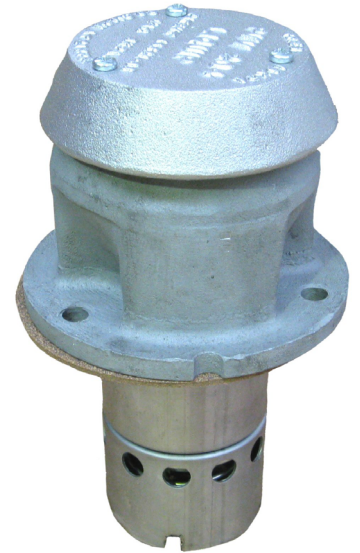

PVV204 shown

## Ordering Information

- **PVV204:** Pressure and vacuum vent, AL, NBR Cork Gasket. Suitable for Australian market.
- **PVV204-ST316:** Pressure and vacuum vent, SS 316 Grade, Teflon Gasket.
- **PVV204-AT:** Pressure and vacuum vent AL, Teflon Gasket.
- **PVV204U:** Pressure and vacuum vent AL, NBR Cork Gasket. Suitable for International markets.

## Specifications

<b>ADJUSTMENT/ SERVICE</b>	Service must be carried out in accordance with AS2809. In particular all seals and gaskets must be replaced and the assembly tested at intervals of no more than 2.5 years. Liquip can provide testing devices to assist.  Ensure that the spring retainer (see overleaf) is installed for correct pressure setting.			
<b>MOUNTING</b>	Metric & Imperial versions available. These may be mounted onto VOH manholes or on to separate weld flanges: <ul style="list-style-type: none"> <li>• Aluminium weld flange: VRB-1</li> <li>• Mild steel weld flange: PVV200-11M</li> <li>• Stainless steel weld flange: PVV200-11S316</li> </ul>			
<b>MATERIALS OF CONSTRUCTION</b>	<ul style="list-style-type: none"> <li>• Aluminium body &amp; poppets (316 grade stainless also available)</li> <li>• Stainless steel housing, shafts and springs.</li> <li>• Nitrile seals (teflon seal also available).</li> </ul>			
<b>WEIGHT</b>	<ul style="list-style-type: none"> <li>• Aluminium versions: 1.96kg</li> <li>• Stainless steel versions: 3.5kg</li> </ul>			
<b>TECHNICAL DATA</b>	<p>NSW Dangerous Goods Branch Approval No N 3554 Q Gas capacity 240m<sup>3</sup>/hr Max recommended liquid loading rate 500 litres/min.</p> <table border="0" style="width: 100%;"> <tr> <td style="vertical-align: top;"> <b>PVV204</b> Complies to AS2809:2020 <ul style="list-style-type: none"> <li>• Pressure setting: 10 to 17kPa</li> <li>• Vacuum setting: 0 to -4kPa</li> <li>• Free air bleed hole in body</li> </ul> </td> <td style="vertical-align: top; padding-left: 20px;"> <b>PVV204U</b> <ul style="list-style-type: none"> <li>• Complies to International codes</li> <li>• Pressure setting: 8 to 12kPa</li> <li>• Vacuum setting: -0.4 to -2.5kPa</li> <li>• No bleed hole in body.</li> </ul> </td> </tr> </table>		<b>PVV204</b> Complies to AS2809:2020 <ul style="list-style-type: none"> <li>• Pressure setting: 10 to 17kPa</li> <li>• Vacuum setting: 0 to -4kPa</li> <li>• Free air bleed hole in body</li> </ul>	<b>PVV204U</b> <ul style="list-style-type: none"> <li>• Complies to International codes</li> <li>• Pressure setting: 8 to 12kPa</li> <li>• Vacuum setting: -0.4 to -2.5kPa</li> <li>• No bleed hole in body.</li> </ul>
<b>PVV204</b> Complies to AS2809:2020 <ul style="list-style-type: none"> <li>• Pressure setting: 10 to 17kPa</li> <li>• Vacuum setting: 0 to -4kPa</li> <li>• Free air bleed hole in body</li> </ul>	<b>PVV204U</b> <ul style="list-style-type: none"> <li>• Complies to International codes</li> <li>• Pressure setting: 8 to 12kPa</li> <li>• Vacuum setting: -0.4 to -2.5kPa</li> <li>• No bleed hole in body.</li> </ul>			
<b>ASSOCIATED EQUIPMENT</b>	<ul style="list-style-type: none"> <li>• See following pages for material variations.</li> </ul>			

# PVV204 PRESSURE & VACUUM VENT

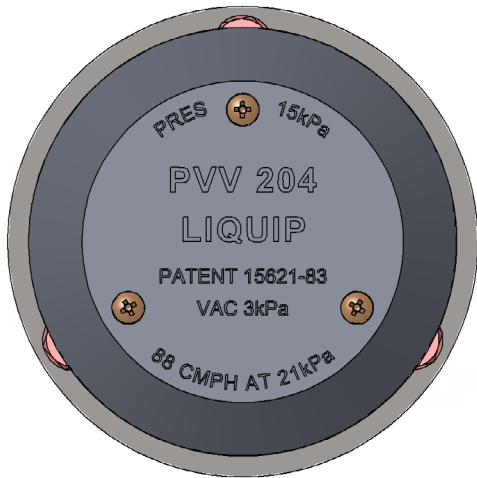

**TOP VIEW  
(AUSTRALIAN MARKINGS)**

PART	COMPLIES TO	PRESSURE & VACUUM SETTINGS
PVV204	AUSTRALIAN STANDARD AS2809-2020	PRESSURE 10 TO 17kPa VACUUM 0 TO -4kPa
PVV204U	INTERNATIONAL CODES	PRESSURE 8 TO 12 kPa VACUUM -0.4 TO -2.5kPa

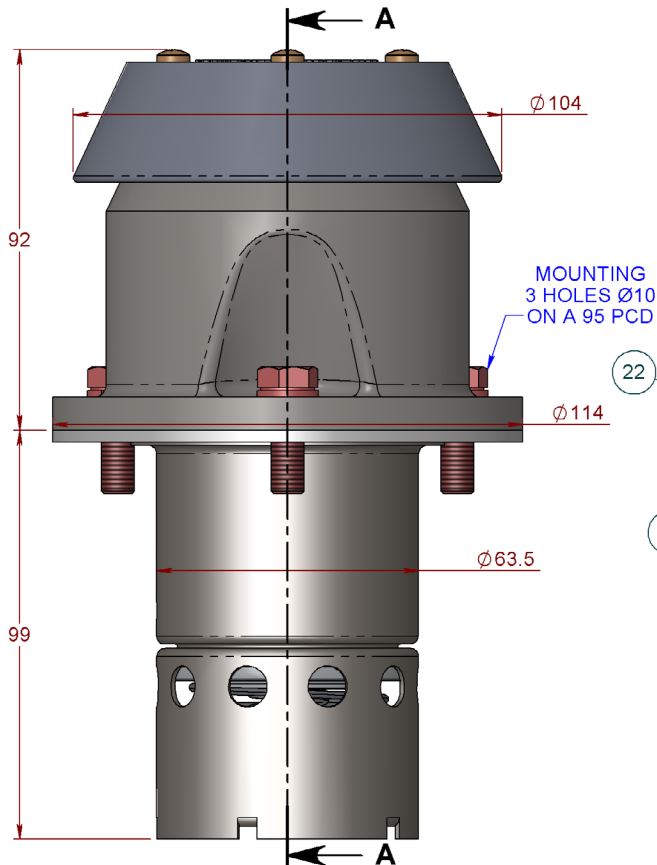

**FRONT VIEW**

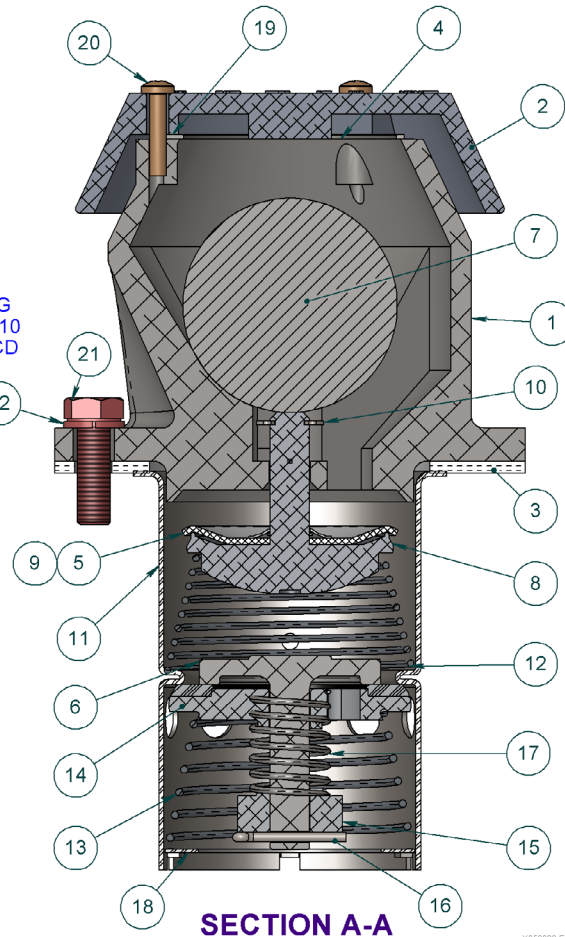

**SECTION A-A**

METERS - VALVES - VENTS - MANHOLES - HOSEREELS - OVERFILL PROTECTION - LOADING ARMS - ELECTRONIC DIPSTICKS



**LIQUIP INTERNATIONAL PTY LTD**  
 148B NEWTON RD, WETHERILL PARK, SYDNEY N.S.W. AUSTRALIA 2164  
 Phone: +61 2 9725-9000 Web: [www.liquip.com](http://www.liquip.com)

**X953800**

Sheet 1 of 2  
Issue: E

# PVV204 PRESSURE & VACUUM VENT

ITEM	PART No.	DESCRIPTION	PVV204	PVV204-ST316	PVV204-AT	PVV204U	MATERIAL
1	PVV204-1	VENT BODY	1	-	1	1	ALUMINIUM
	PVV204-1S	BODY	-	1	-	-	ST STEEL
2	PVV204-2	COVER	1	-	1	-	ALUMINIUM
	PVV204-2S	COVER	-	1	-	-	ST STEEL
	PVV204-2U	COVER USA MARKINGS	-	-	-	1	ALUMINIUM
3	0658	GASKET	1	-	-	1	NBR-CORK
	4293	GASKET	-	1	1	-	EXP-PTFE
4	PVV204-4S	GAUZE	1	1	1	1	ST STEEL
5	4645	ROLLOVER SEAL DISC	-	1	1	-	PTFE
6	PVV204-8	PRESSURE POPPET	1	-	1	1	ALUMINIUM
	PVV204-8S	PRESSURE POPPET	-	1	-	-	ST STEEL
7	PVV204-3	ROLLOVER BALL	1	-	1	1	LEAD
	PVV204-3S	ROLLOVER BALL	-	1	-	-	ST STEEL
8	PVV204-7	ROLLOVER POPPET WITH BONDED SEAL	1	-	-	1	ALUMINIUM
	PVV204-7S	STAINLESS STEEL ROLLOVER POPPET	-	1	-	-	ST STEEL
	PVV204-7C	ROLLOVER POPPET	-	-	1	-	ALUMINIUM
9	6545	PUSH-ON CLIP	-	1	1	-	ST STEEL
10	55026	E-CLIP METRIC	1	1	1	1	ST STEEL
11	PVV204-6-316	HOUSING SPUN	1	1	1	1	ST STEEL
12	0057	SPRING COMPRESSION	1	-	1	1	ST STEEL
	4435	SPRING COMPRESSION	-	1	-	-	ST STEEL
13	0058	SPRING COMPRESSION	1	-	1	1	ST STEEL
	4436	SPRING COMPRESSION	-	1	-	-	ST STEEL
14	PVV204-9	VACUUM POPPET	1	-	-	1	ALUMINIUM
	PVV204-9S	VACUUM POPPET	-	1	-	-	ST STEEL
	PVV204-9C	VACUUM POPPET	-	-	1	-	ALUMINIUM
15	PVV204-13	SPRING RETAINER	1	-	1	-	ALUMINIUM
	PVV204-15	SPRING RETAINER	-	-	-	1	ALUMINIUM
	4352	WASHER FLAT	-	1	-	-	ST STEEL
16	0764	SPLIT PIN	1	-	1	1	ST STEEL
	2764	ROD TIG (SPLIT PIN SUBSTITUTE)	-	1	-	-	ST STEEL
17	0302	SPRING COMPRESSION	1	-	1	-	ST STEEL
	4437	SPRING COMPRESSION	-	1	-	-	ST STEEL
	4447	SPRING COMPRESSION	-	-	-	1	ST STEEL
18	PVV204-20-316	SPRING RETAINER	-	1	-	-	ST STEEL
	PVV204-20	SPRING RETAINER	1	-	1	1	ST STEEL
19	PVV204-5	GAUZE RETAINER	1	-	1	1	STEEL
	PVV204-5S	GAUZE RETAINER	-	1	-	-	ST STEEL
20	6645	TAPTITE SCREW METRIC	3	-	3	3	Z/P STEEL
	55069	SCREW METRIC	-	3	-	-	ST STEEL
21	55057	SETSCREW METRIC	1	3	3	3	ST STEEL
22	5362	WASHER SPRING	1	3	3	3	ST STEEL
23	PVV204-18	INSTRUCTION LEAFLET	1	1	1	1	PAPER
24	6425	INSTRUCTION LEAFLET	-	1	1	-	PAPER

METERS - VALVES - VENTS - MANHOLES - HOSEREELS - OVERFILL PROTECTION - LOADING ARMS - ELECTRONIC DIPSTICKS



**LIQUIP INTERNATIONAL PTY LTD**  
 148B NEWTON RD, WETHERILL PARK, SYDNEY N.S.W. AUSTRALIA 2164  
 Phone: +61 2 9725-9000 Web: www.liquip.com

**X953800**

Sheet 2 of 2  
 Issue: E