

LBM800 STYLE LOW PROFILE/UNLOAD ARM

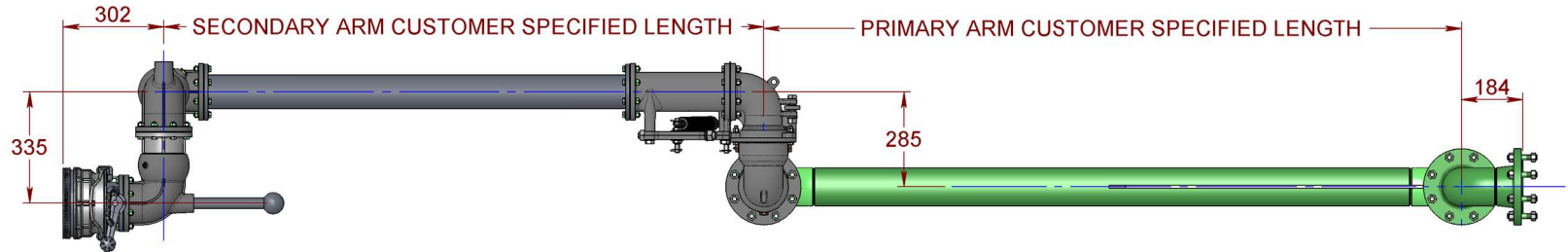

NOTE:
ALL LOADING ARMS ARE INDIVIDUALLY DESIGNED
LIFT-O-MAT STRUT STRENGTH DEPENDS ON ARM LENGTH,
MATERIAL AND CONTENTS EG LIQUID OR VAPOUR.
EACH JOB MUST SPECIFY THE STRUTS TO BE USED.

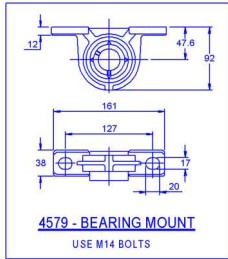
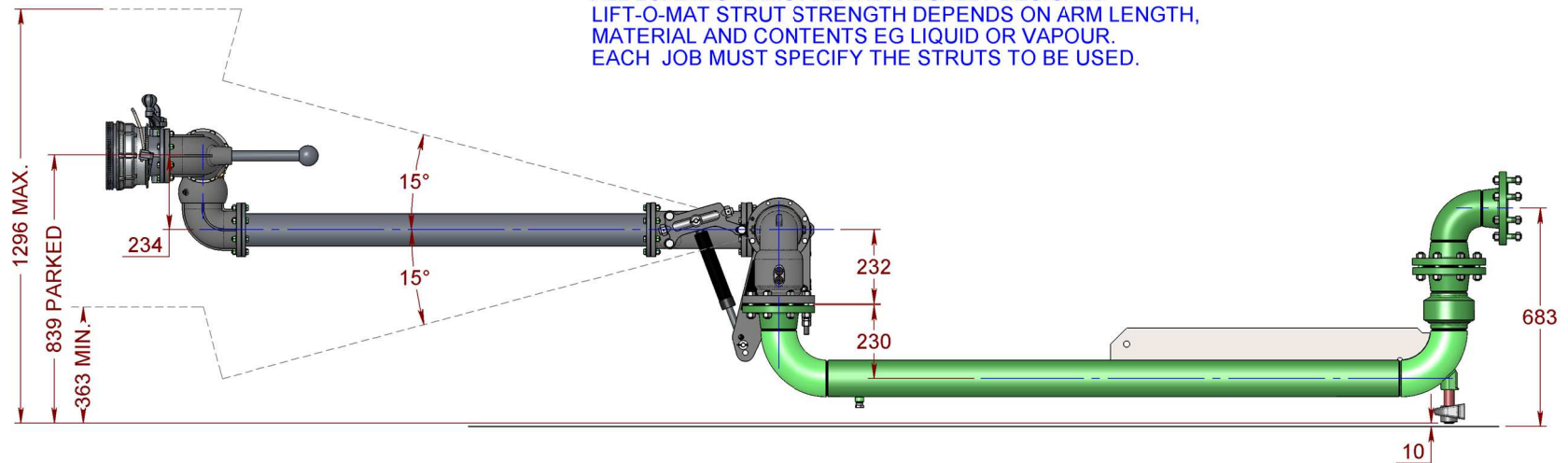
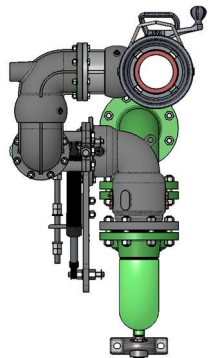

METERS - VALVES - VENTS - MANHOLES - PUMPS - HOSEREELS - OVERFILL PROTECTION - LOADING ARMS - ELECTRONIC DIPSTICKS



LIQUIP INTERNATIONAL PTY LTD

13 HUME ROAD SMITHFIELD SYDNEY N.S.W. AUSTRALIA 2164

Phone: +61 2 9725 9000 Web: www.liquip.com

X751818

Sheet 1 of 2
Issue: A

LBM800 STYLE LOW PROFILE/UNLOAD ARM

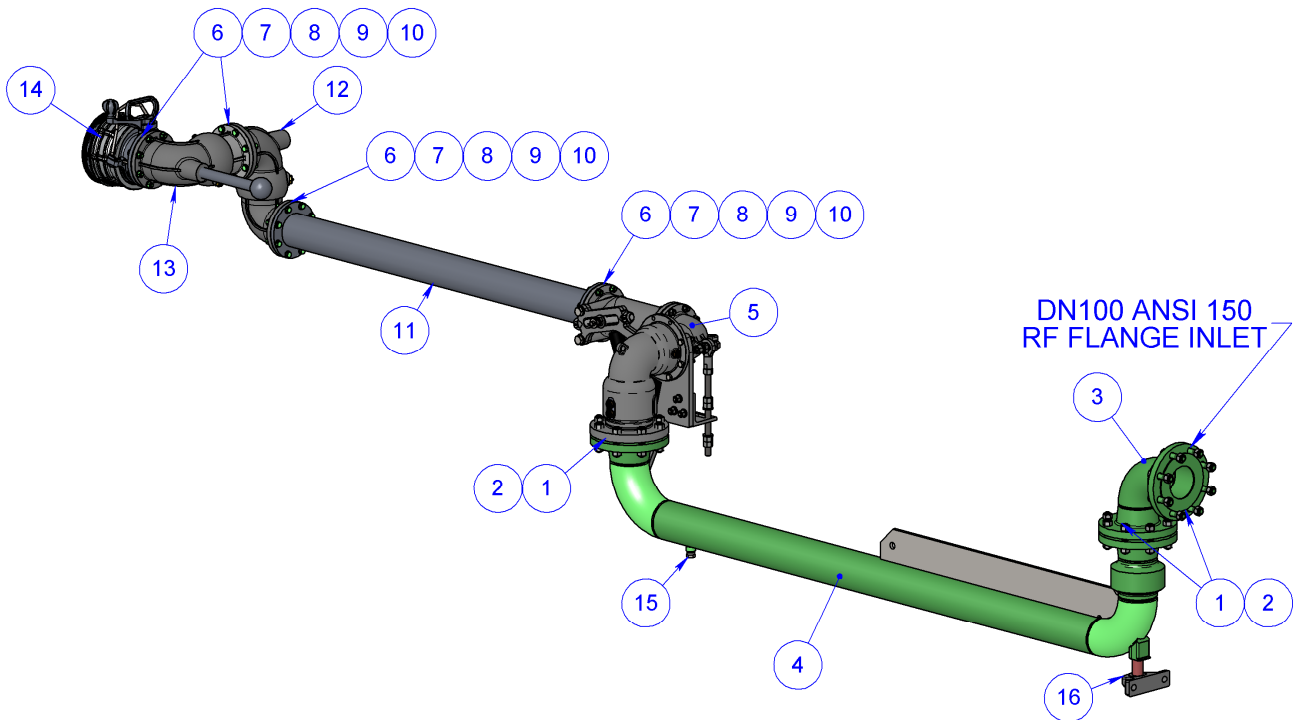

ITEM	PART No.	DESCRIPTION	QTY	MATERIAL	GRADE
1	4235	GASKET 4" ANSI 150	3	KLINGERSIL	C4430
2	4892	STUD HI-TEMP WITH 2 x NUTS	24	Z/P STEEL	B7 & 2H
3	FIE100-S150WW	FLANGED INLET ELBOW	1	STEEL	A105 & A234 WPB
4	FABRICATE	PRIMARY ARM 100mm	1	STEEL	NOTES
5	LBM800	LIQUIP BALANCE MECHANISM	1	CAST STEEL	4130
6	4248	GASKET TTMA 100mm (4")	4	KLINGERITE	C4430
7	6745	BOLT METRIC	32	Z/P STEEL	PC8.8
8	6744	NUT METRIC	32	Z/P STEEL	PC8
9	5261	WASHER SPRING	32	Z/P STEEL	250
10	5288	WASHER FLAT	64	Z/P STEEL	250
11	L219A-1280	HORIZONTAL SPOOL Ø101.6 x 6.35mm WALL	1	ALUMINIUM	6061-T6
12	VNI-A4VG	INTERMEDIATE SWIVEL	1	ALUMINIUM	AA601
13	VNC-A4VG	COUPLER SWIVEL 100mm TTMA	1	ALUMINIUM	AA601
14	LYNX850	API COUPLER	1	ALUMINIUM	AA601
15	0614	PLUG HEX HEAD	1	Z/P STEEL	350
16	4579Z	BEARING & BLOCK	1	IRON	DUCTILE